



HBS-400-4 SINGLE TOWER DESICCANT AIR DRYER GENERAL ARRANGEMENT

TOLERANCES UNLESS OTHERWISE SPECIFIED:

- FRACTIONS = ± 1/4 "
- ANGLES = ± 3°
- INCHES = ± 1/2 "
- FINISH = 250

THE SPECIFICATIONS AND DRAWINGS DISCLOSED HEREIN ARE THE SOLE PROPERTY OF ALTEC AIR, AND SHALL NOT BE COPIED OR USED AS THE BASIS FOR SALE OR MANUFACTURE WITHOUT EXPRESS WRITTEN PERMISSION.

REVISION LOG

REV.	ECO.	DESCRIPTION	DATE	APPROVED
G	1123	PRODUCTION UPDATES	4/20/2021	WS

DRAWING NO.

AT20-368

REV. **G**

DRAWN: MR DATE: 9/1/2015
 CHECKED: DATE:

SCALE: N/A SHEET: 1 OF 2

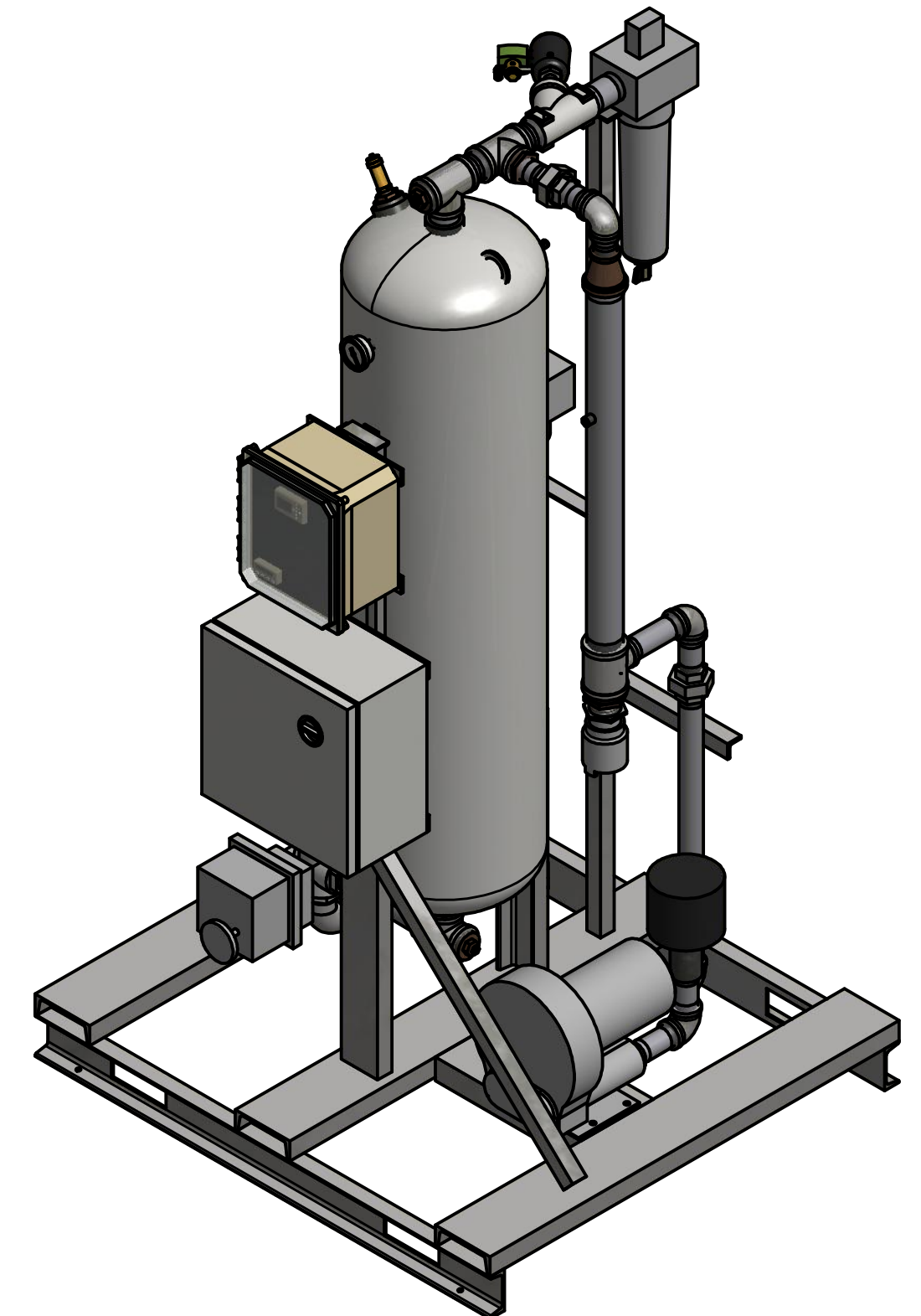
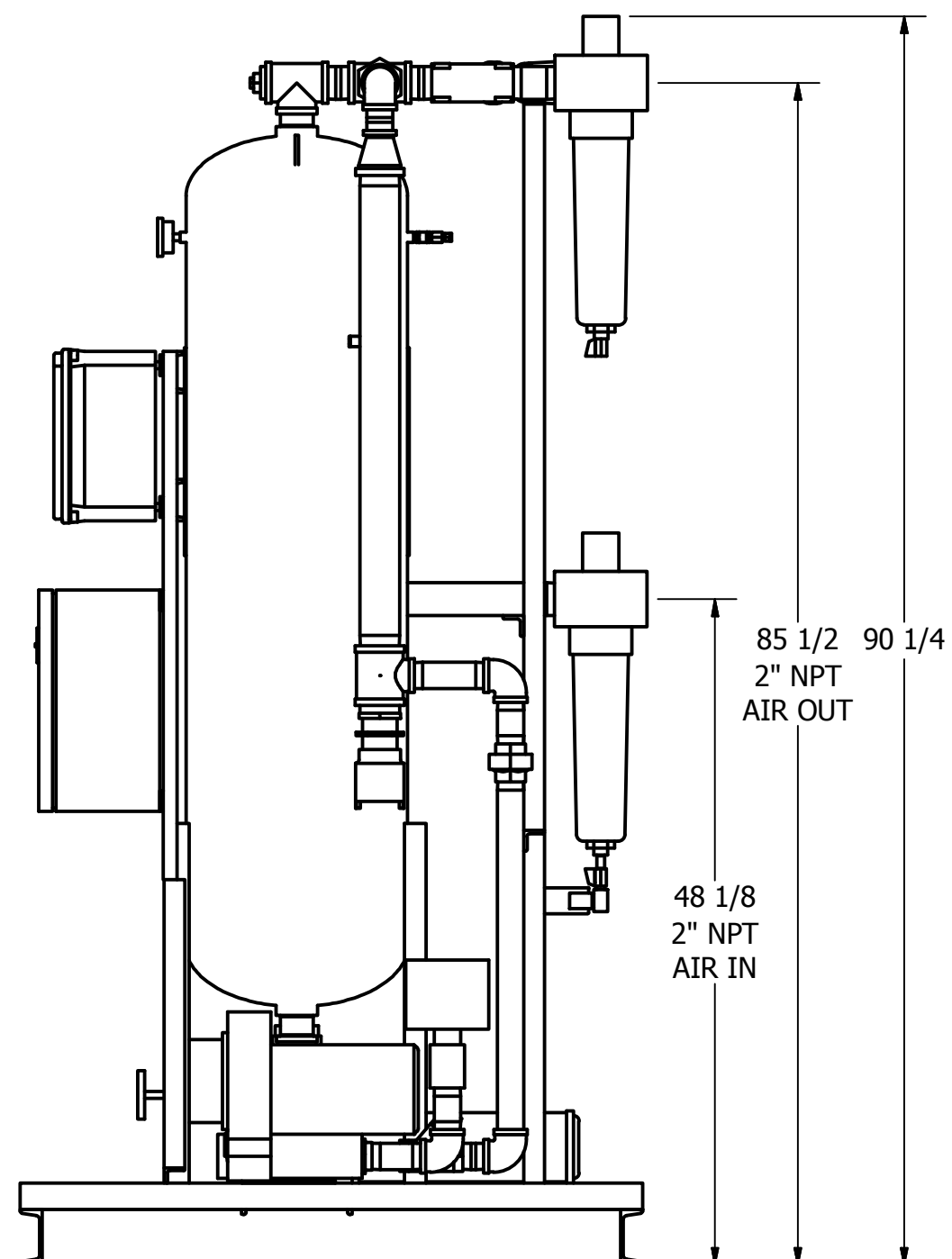
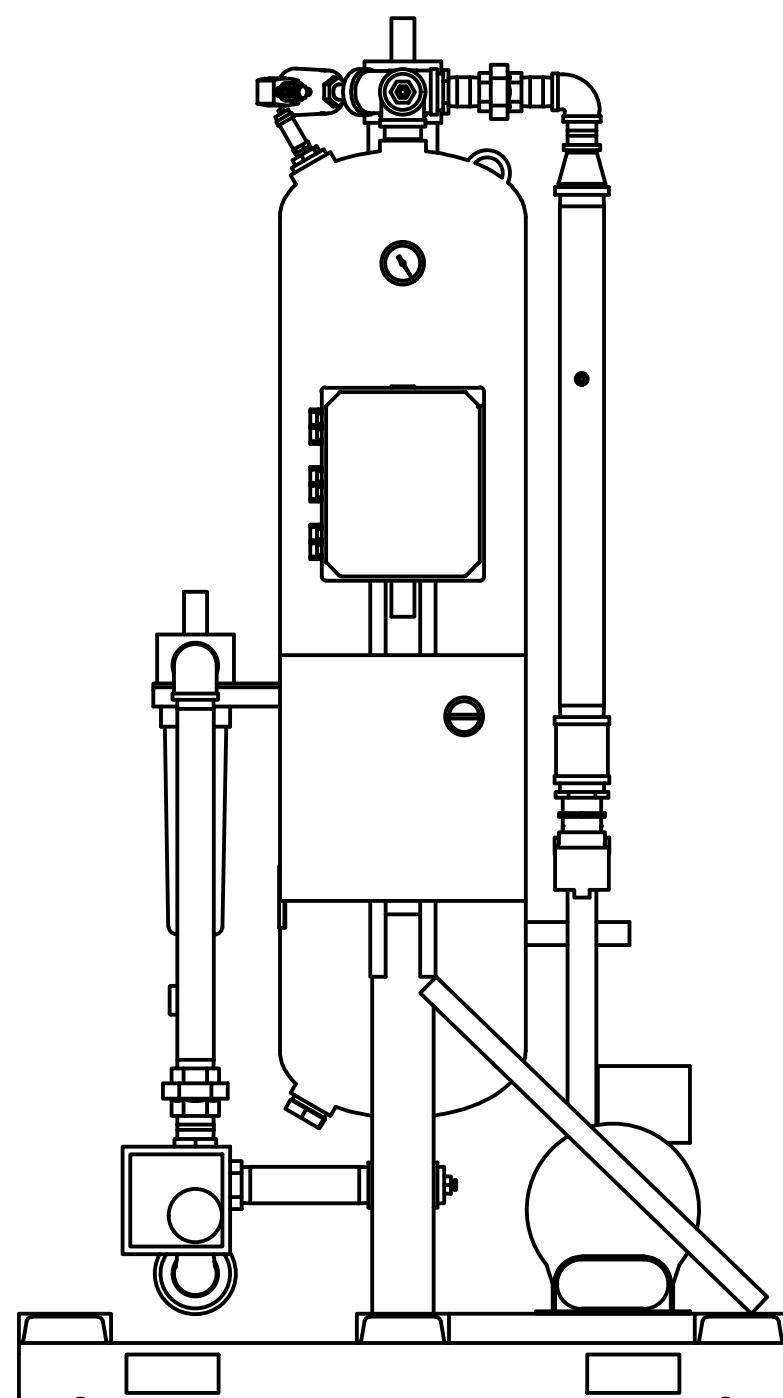
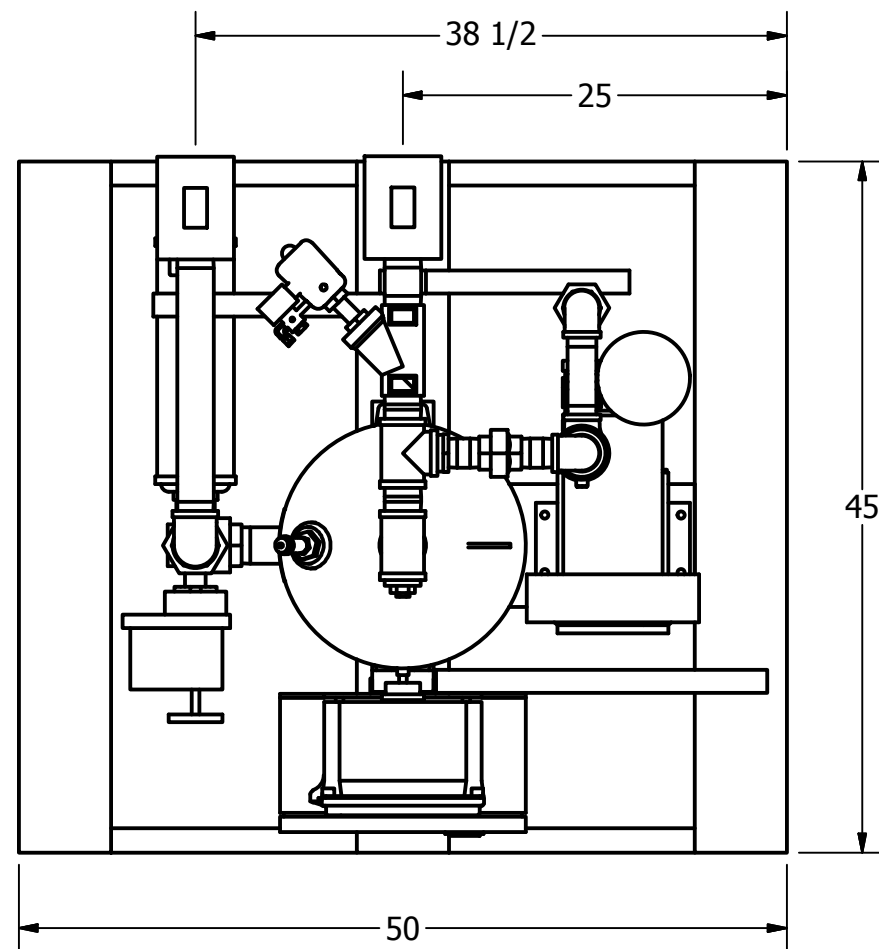

PRELIMINARY



HBS-400-4 SINGLE TOWER DESICCANT AIR DRYER GENERAL ARRANGEMENT

TOLERANCES UNLESS OTHERWISE SPECIFIED:

- FRACTIONS = ± 1/4 "
- ANGLES = ± 3°
- INCHES = ± 1/2 "
- FINISH = 250

THE SPECIFICATIONS AND DRAWINGS DISCLOSED HEREIN ARE THE SOLE PROPERTY OF ALTEC AIR, AND SHALL NOT BE COPIED OR USED AS THE BASIS FOR SALE OR MANUFACTURE WITHOUT EXPRESS WRITTEN PERMISSION.

REVISION LOG

REV.	ECO.	DESCRIPTION	DATE	APPROVED
G	1123	PRODUCTION UPDATES	4/20/2021	WS

DRAWING NO. **AT20-368** REV. **G**

DRAWN: MR DATE: 9/1/2015
CHECKED: DATE:

SCALE: N/A SHEET: 2 OF 2

PARTS LIST

ITEM	QTY	DESCRIPTION
1	1	ANGLE BODY VALVE, OUTLET
2	1	PARTICULATE AFTER-FILTER
3	1	RELIEF VALVE, TANK
4	1	MOISTURE INDICATOR
5	1	PRESSURE GAUGE, TANK
6	1	3 KW HEATER
7	1	3-WAY BALL VALVE, INLET
8	1	COALESCER PRE-FILTER
9	1	TIMED DRAIN
10	1	MUFFLER, EXHAUST
11	1	1 HP BLOWER
12	1	FILTER, BLOWER
13	1	CHECK VALVE, BLOWER
14	300 LBS	DESICCANT

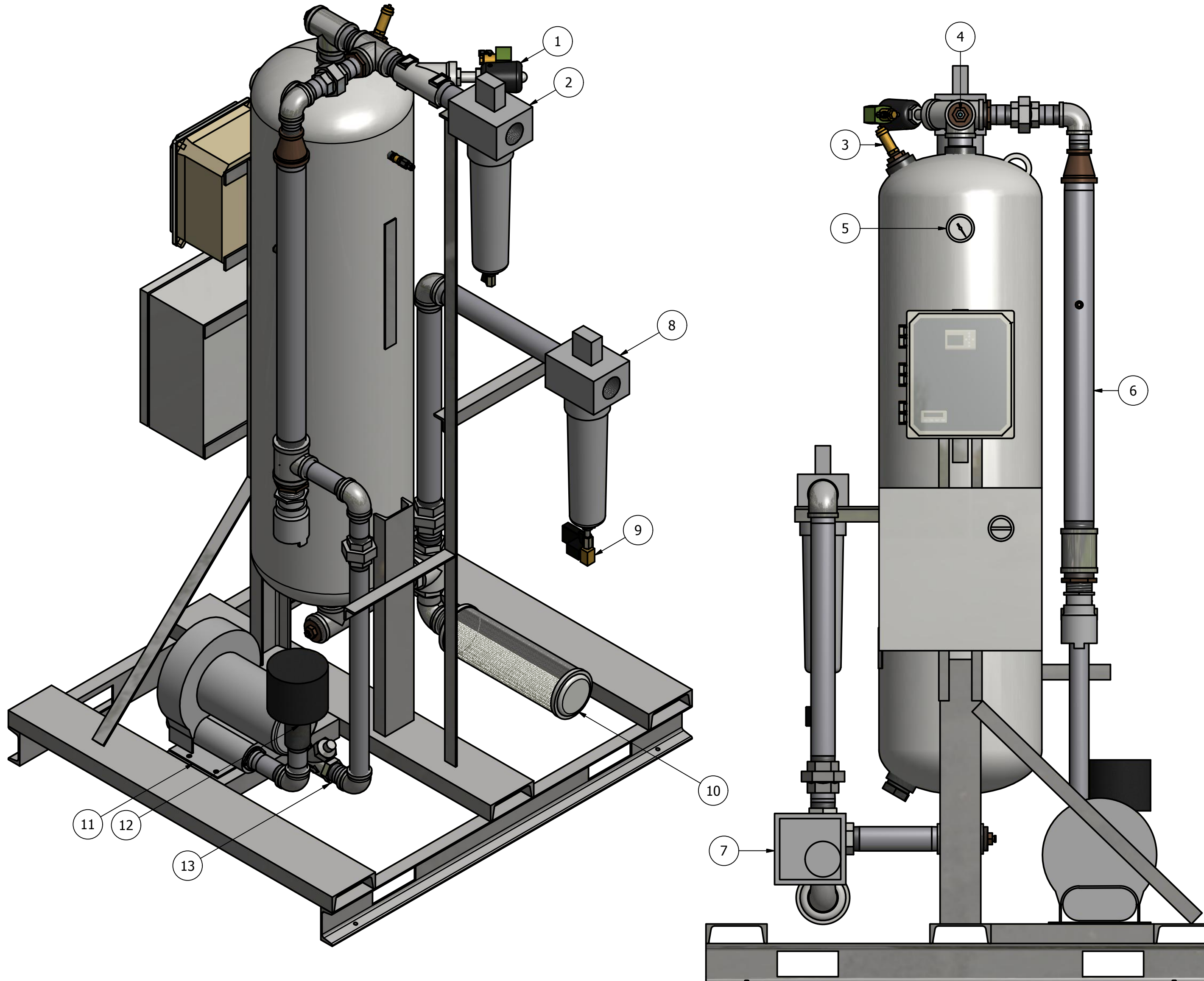

PRELIMINARY